

Service Schematics

NOKIA

6233 6234

Introduction

Exploded view and component disposal

IMPORTANT:

This document is intended for use by authorized NOKIA service centers only.

“Service Schematics” was created with focus on customer care. The purpose of this document is to provide further technical repair information for NOKIA mobile phones on Level 3/4 service activities. The “Signal overview” page gives a good and fast overview about the most important signals and voltages on board. Saving process time and improving the repair quality is the aim of this document. It is to be used additionally to the service manual and other training or service information such as Service Bulletins.

All measurements were made using following equipment:

Nokia repair SW	: Phoenix version 2006.04.6.130
Oscilloscope	: Fluke PM 3380A/B
Spectrum Analyzer	: Advantest R3162 with an analog probe
RF-Generator / GSM Tester	: Rhode & Schwarz CMU 200
Multimeter	: Fluke 73 Series II

While every endeavour has been made to ensure the accuracy of this document, some errors may exist. If the reader finds any errors, NOKIA shall be notified in writing.

Please send E-Mail to: training.sace@nokia.com

Copyright © NOKIA

This material, including documentation and any related computer programs is protected by copyright, controlled by NOKIA. All rights are reserved. Copying, including reproducing, modifying, storing, adapting or translating any or all of this material requires the prior written consent of NOKIA. This material also contains company confidential information, which may not be disclosed to others without the prior written consent of NOKIA.

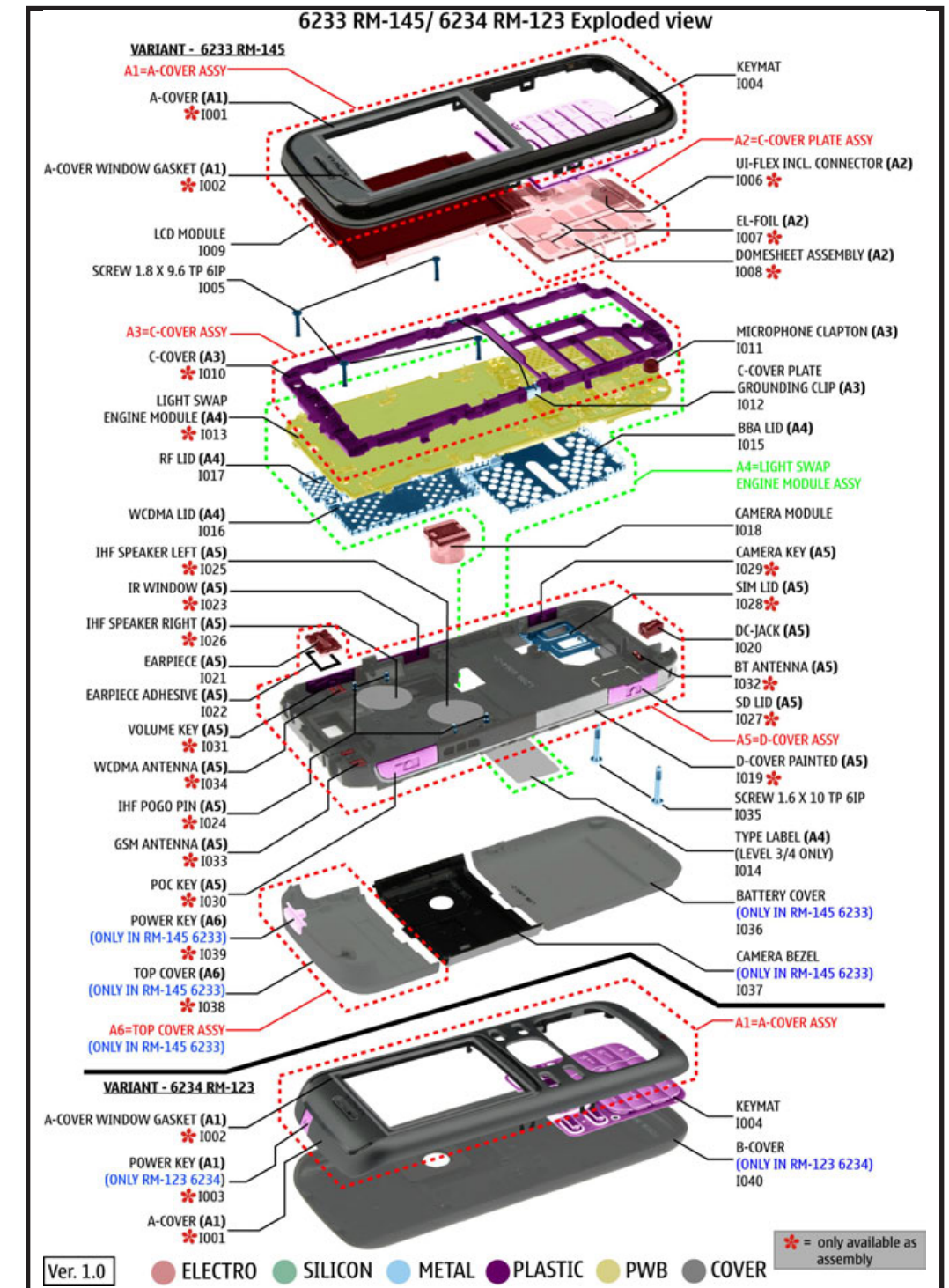
RM-145

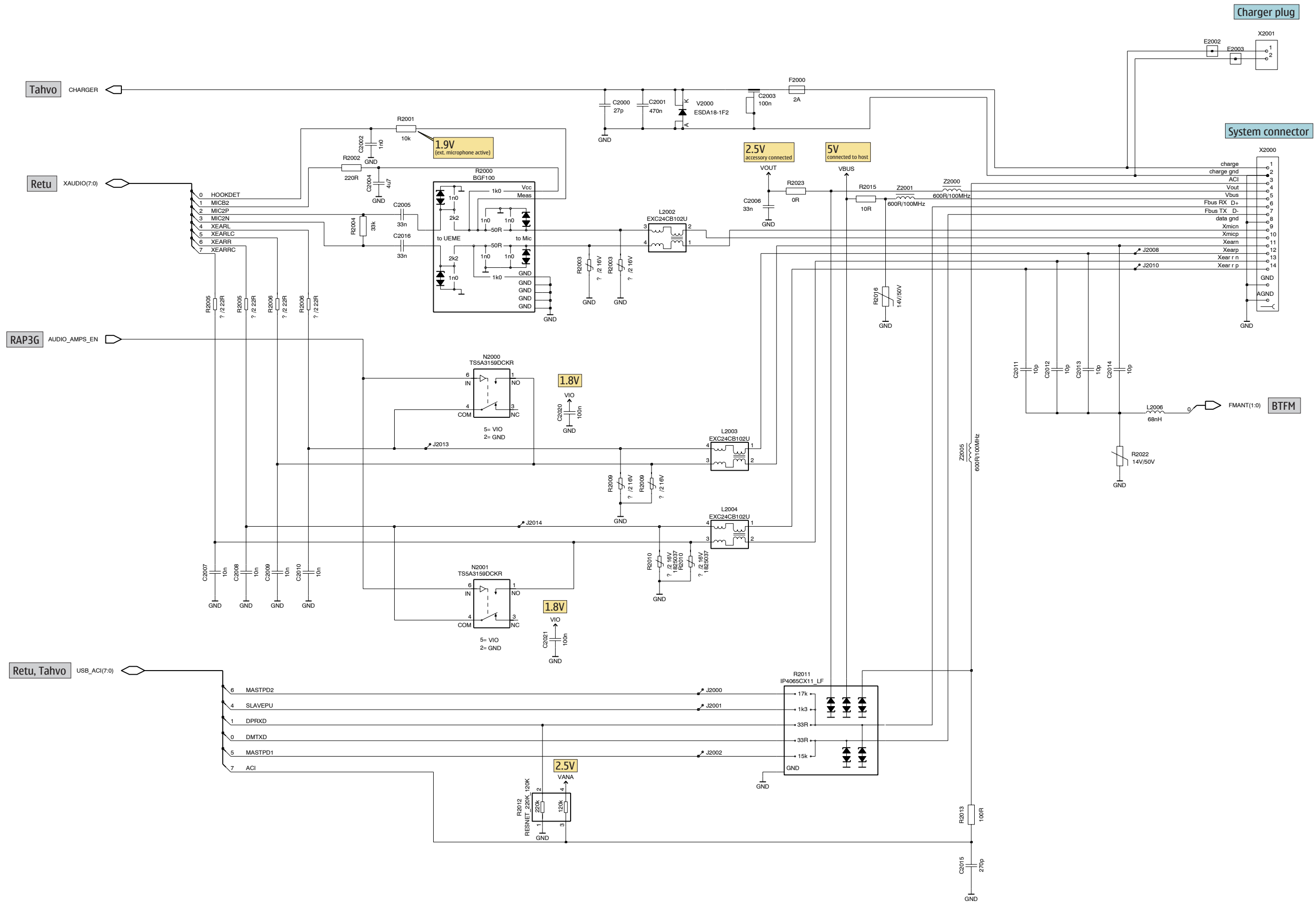


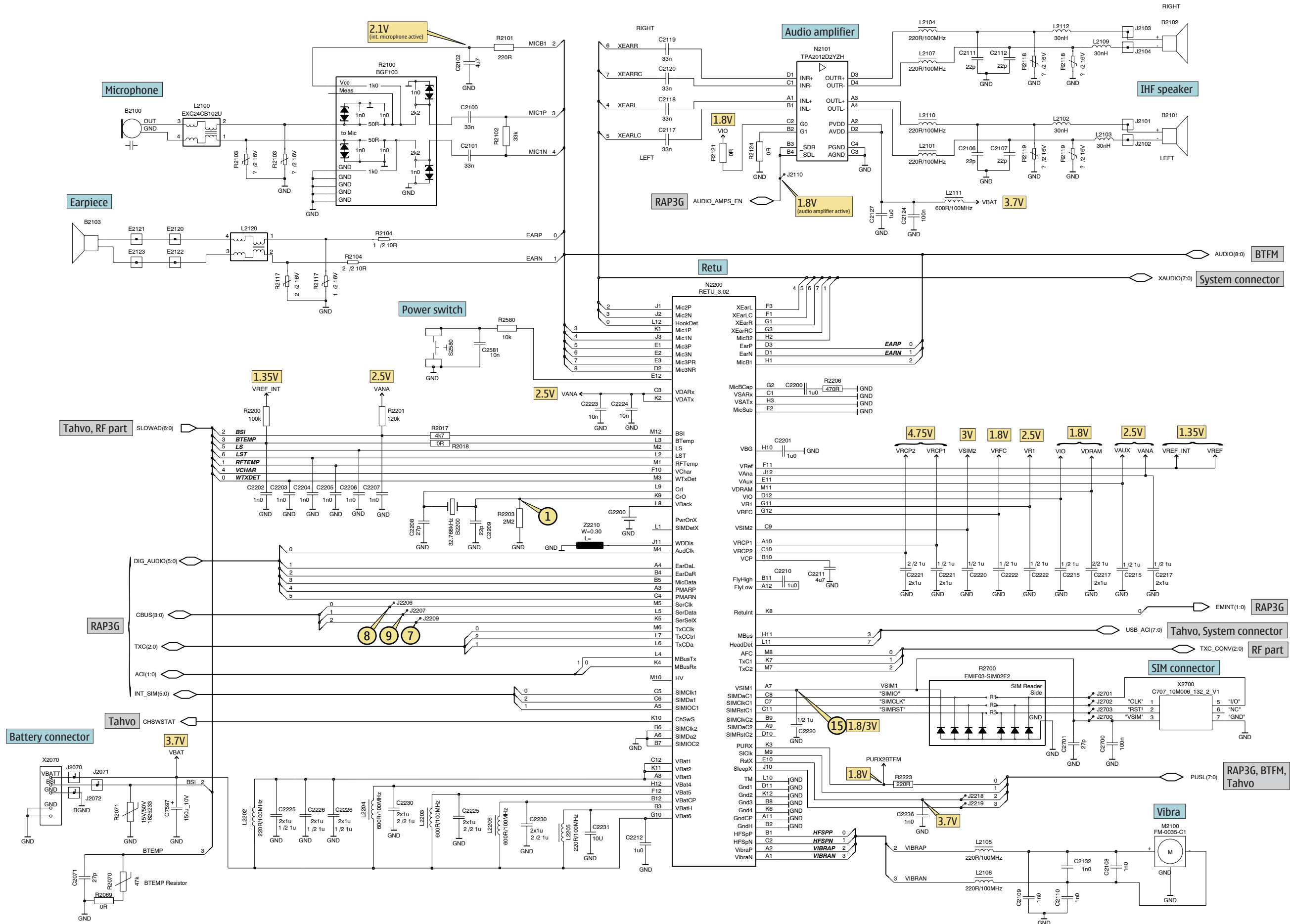
RM-123

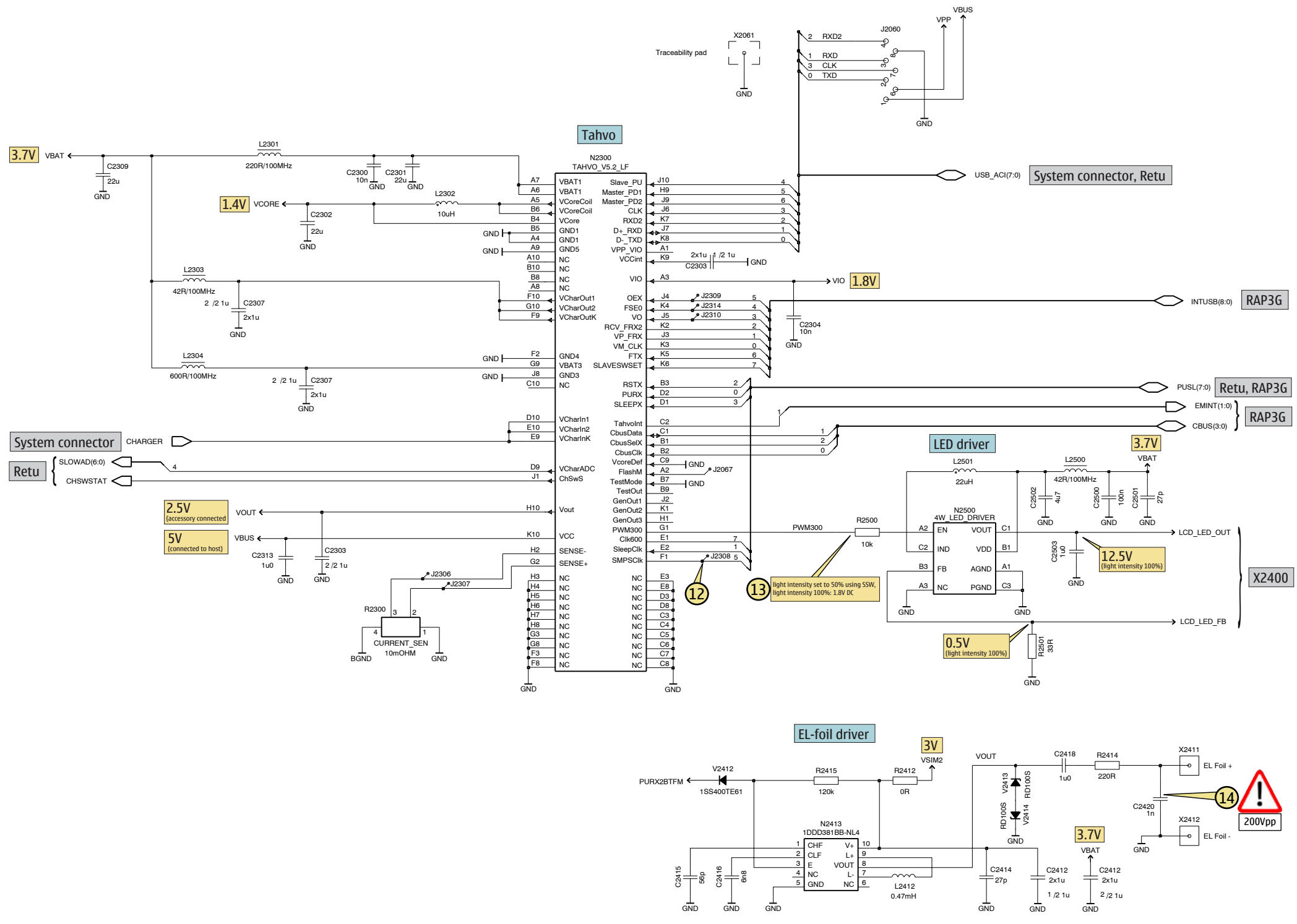


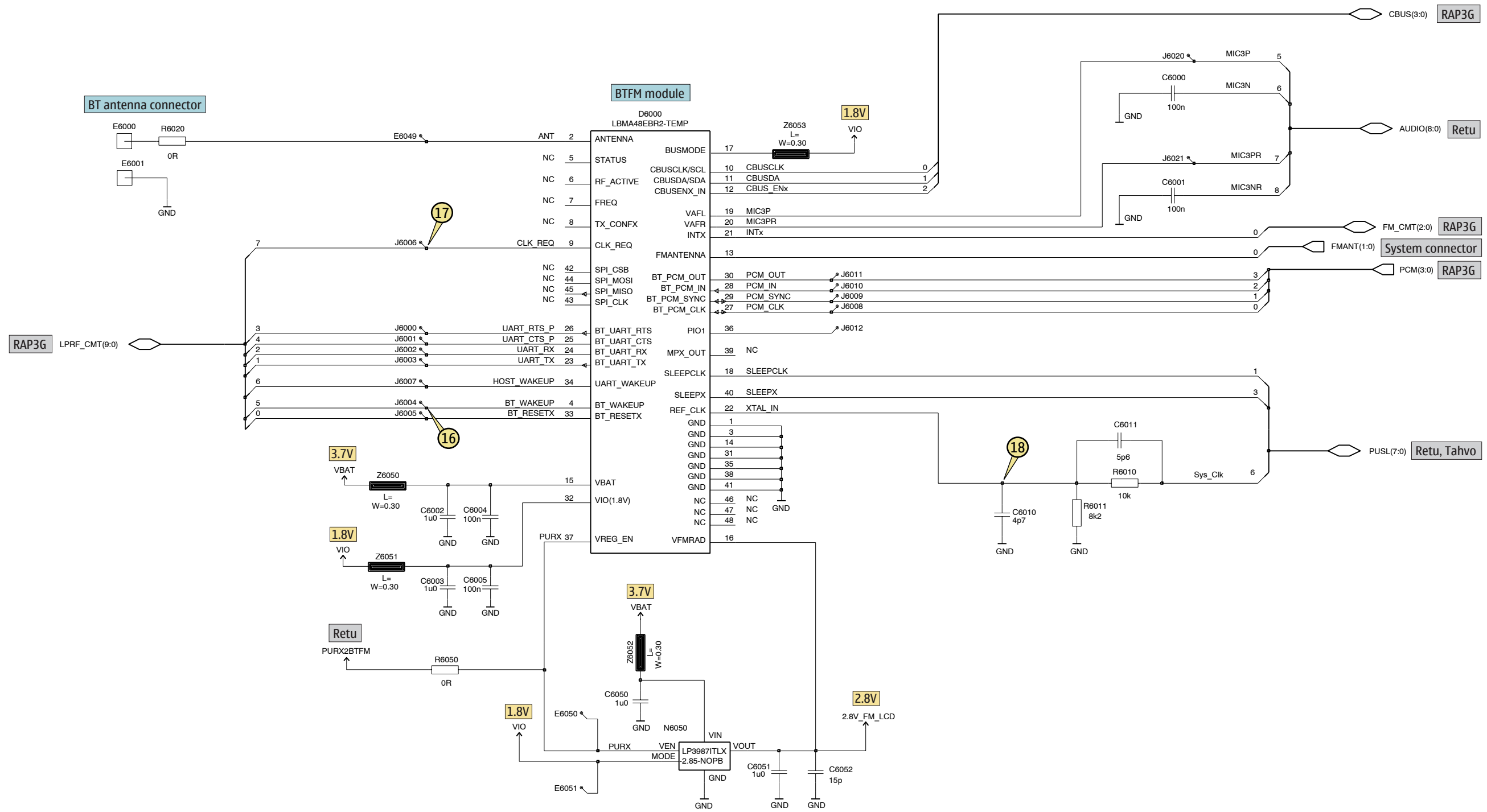
Table of Content	Page
Front page	1
System connector	2
Retu, SIM, Audio	3
Tahvo, LED/EL driver	4
RAP3G, Memories, miniSD	5
BTFM	6
Camera	7
RF part	8
Signal overview	9
Component finder	10

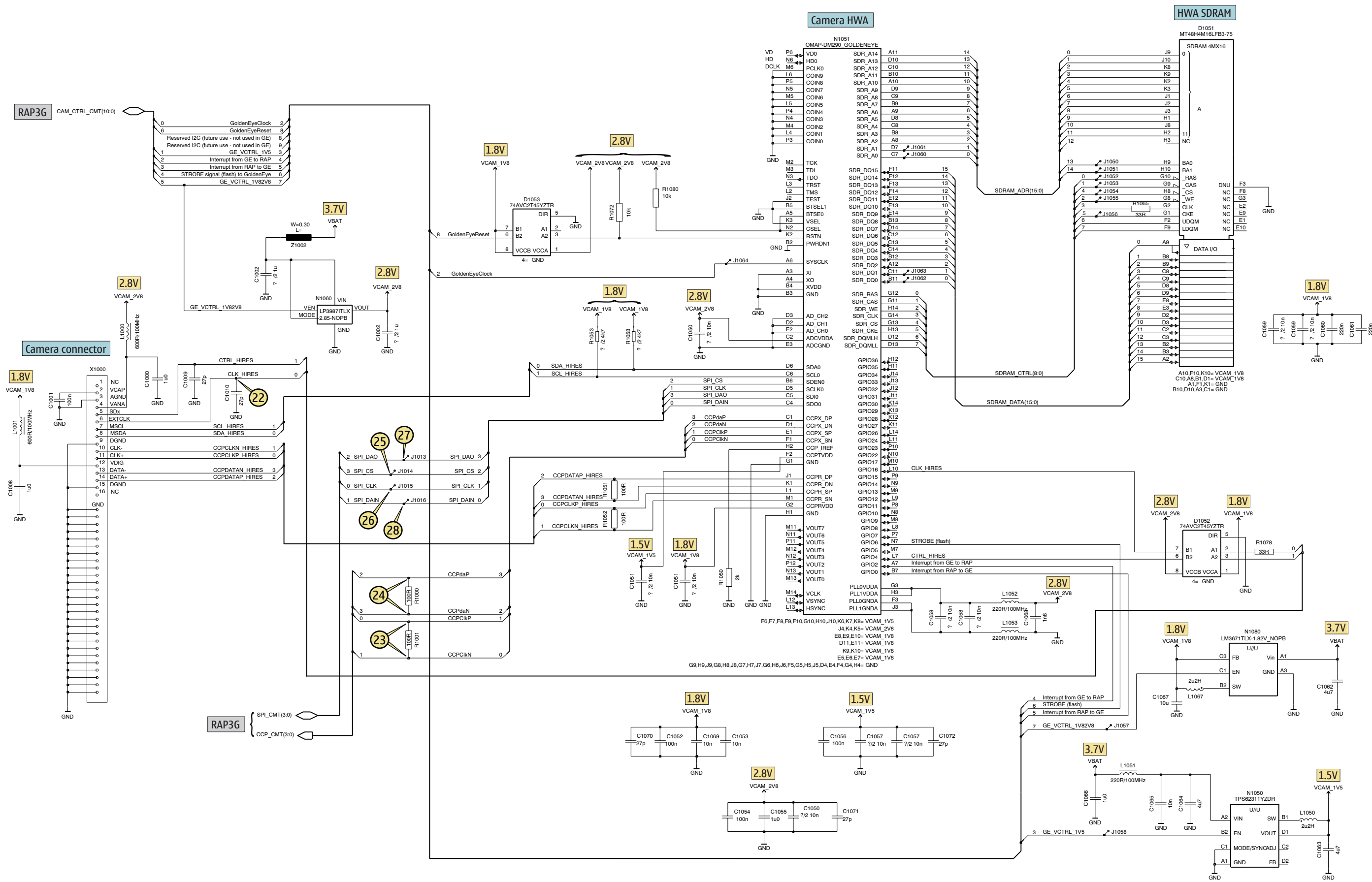


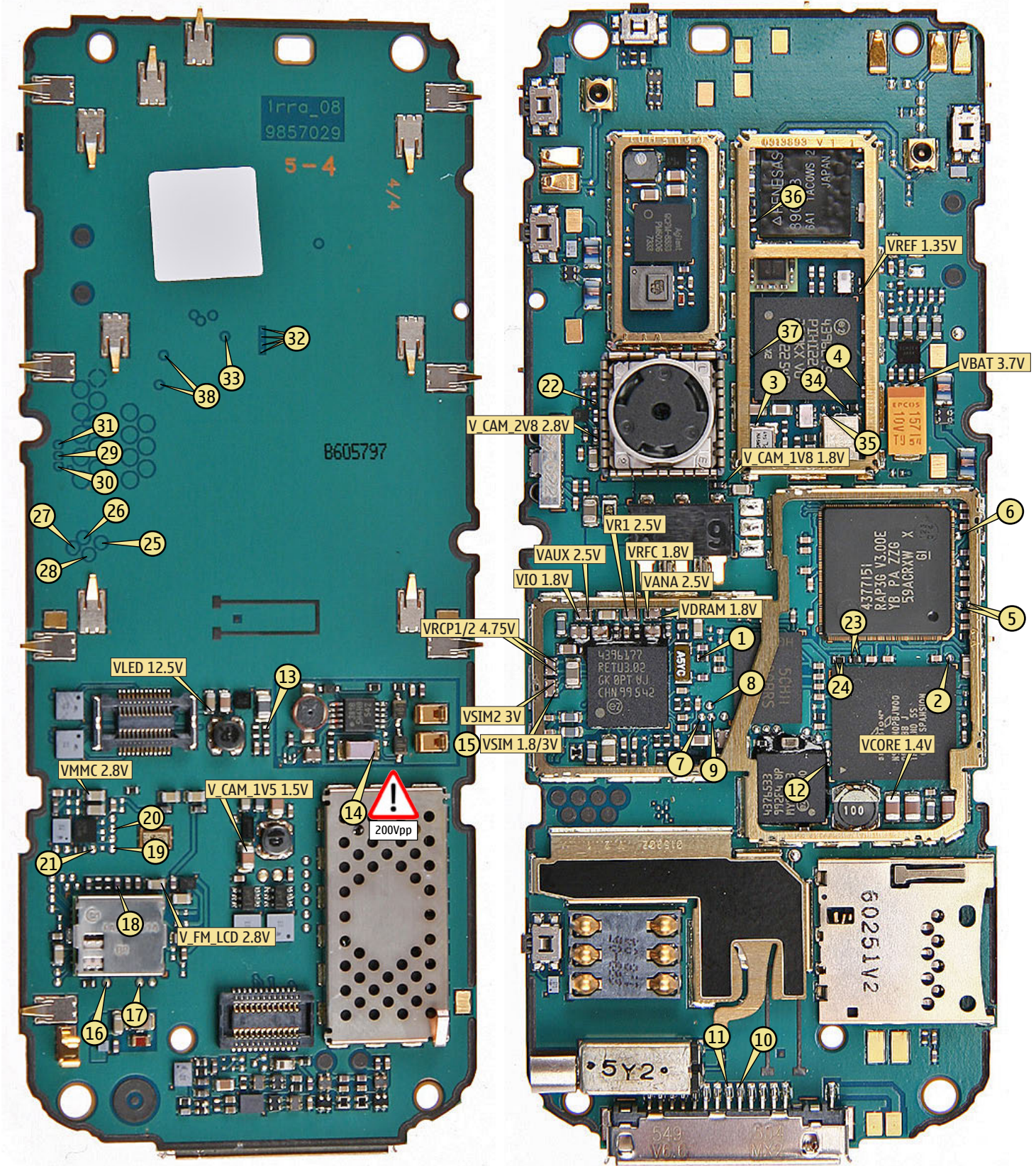
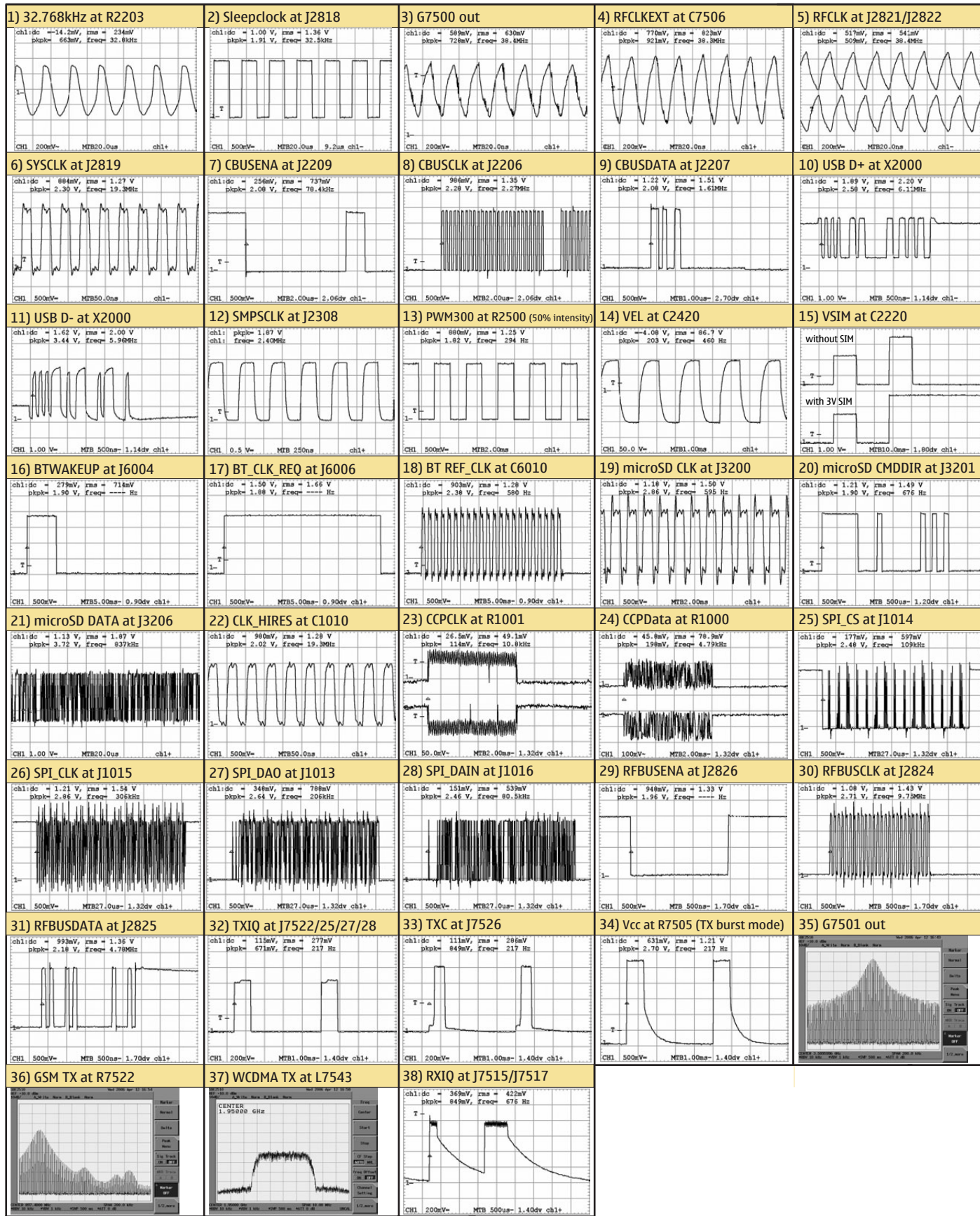












B	C2221	I9	C7504	M5	J2821	J2	L2108	H9	R2102	G7	X8015	S8	
B2200	I7	C2222	J8	C7505	M5	J2822	J2	L2109	P8	R2103	B6	X8016	I9
C	C2223	H8	C7506	N3	J2823	K2	L2110	O3	R2104	G8	X8017	N2	
C1000	M8	C2224	H7	C7507	P3	J2824	M2	L2111	P3	R2117	S7	X8018	I2
C1001	M8	C2225	J8	C7508	M3	J2825	M2	L2112	P8	R2118	P9	X8019	O3
C1002	N8	C2226	J8	C7509	M3	J2826	M2	L2120	S7	R2119	M2	X8020	S3
C1008	L6	C2230	J7	C7510	M4	J3100	M2	L2202	J9	R2121	O3	X8021	N9
C1009	M8	C2231	H8	C7511	N3	J3101	N2	L2203	J8	R2124	P3	X8023	B2
C1010	N8	C2236	J8	C7512	M4	J3102	N2	L2204	J7	R2200	H7	Z	
C1050	C9	C2300	G2	C7514	P4	J3103	N2	L2205	G8	R2201	J7	Z1002	N8
C1051	D9	C2301	F2	C7515	P4	J3104	M2	L2206	J7	R2203	I6	Z2000	A4
C1052	E9	C2302	F3	C7516	M3	J3105	M2	L2301	F2	R2206	G8	Z2001	B5
C1053	C7	C2303	H6	C7521	R5	J3110	M2	L2302	F4	R2223	H7	Z2005	B4
C1054	G8	C2304	F4	C7541	Q7	J3111	L2	L2303	G6	R2300	K7	Z2210	G7
C1055	F8	C2307	G6	C7542	R7	J3112	M3	L2304	H5	R2400	G3	Z2403	H2
C1056	D9	C2309	F3	C7543	Q7	J3113	M3	L2400	G4	R2412	I8	Z2404	H2
C1057	D9	C2313	H5	C7544	P6	J3114	L3	L2401	G4	R2414	H7	Z2580	D6
C1058	F8	C2405	G4	C7545	P7	J3115	M3	L2412	H6	R2415	I7	Z2581	D5
C1059	E9	C2406	G4	C7547	N5	J3116	M3	L2500	H5	R2500	H6	Z2597	R2
C1060	M8	C2412	G6	C7597	M3	J3117	M3	L2501	H5	R2501	H5	Z2598	T9
C1061	C7	C2414	H6	D	J3118	N2	L3200	G2	R2580	T7	Z2599	P9	
C1062	G8	C2415	I8	D1051	C8	J3119	N3	L7500	N3	R2600	L8	Z2600	C9
C1063	F5	C2416	I8	D1052	F8	J3120	M2	L7501	P4	R2700	E8	Z3004	H4
C1064	G6	C2418	G7	D1053	C9	J3200	F3	L7502	P4	R2800	I2	Z3005	H2
C1065	F6	C2420	H7	D2800	K3	J3201	F3	L7520	R5	R3000	H4	Z3006	J6
C1066	G5	C2500	H5	D3000	I5	J3202	F3	L7540	R7	R3200	F2	Z3007	J6
C1067	F7	C2501	H6	D3001	H3	J3203	F3	L7542	O7	R3204	G2	Z3210	G2
C1068	G8	C2502	H5	D6000	D3	J3204	F2	L7543	N5	R3205	F2	Z3211	G3
C1069	C7	C2503	H4	F	J3205	F2	M	R3221	E5	Z3212	G2		
C1070	E9	C2581	T7	F2000	B3	J3206	F2	M2100	B7	R6010	E2	Z6050	D4
C1071	D8	C2600	L8	G	J3221	F5	N	R6011	E3	Z6051	E2		
C1072	E9	C2601	L8	G2200	D5	J6000	E2	N1050	F5	R6020	C2	Z6052	E4
C2000	B3	C2602	L8	G7500	M5	J6001	E2	N1051	E8	R6050	H7	Z6053	D4
C2001	C3	C2603	L8	G7501	M4	J6002	E2	N1051	E8	R7500	M5	Z7500	P5
C2002	B6	C2700	E8	J	J6003	E2	N1060	M8	R7501	P3	Z7520	Q3	
C2003	C3	C2701	E8	J1000	P2	J6004	C3	N1080	G8	R7503	M4	Z7540	P7
C2004	B5	C2800	J4	J1001	Q2	J6005	D2	N2000	E5	R7504	M5		
C2005	A5	C2801	J2	J1002	Q2	J6006	C3	N2001	E6	R7505	N4		
C2006	D5	C2802	K4	J1003	P2	J6007	C2	N2101	N3	R7520	Q5		
C2007	B7	C2803	J2	J1013	K2	J6008	E2	N2200	I8	R7522	Q5		
C2008	B8	C2804	K2	J1014	K3	J6009	E2	N2300	G5	R7540	Q5		
C2009	A6	C2805	I2	J1015	K2	J6010	E2	N2300	G5	R7541	R6		
C2010	B7	C2806	I3	J1016	K2	J6011	E2	N2413	H7	R7542	P7		
C2011	B8	C2807	I2	J1050	E6	J6012	C3	N2500	H5	R7543	O6		
C2012	B7	C2808	J2	J1051	C8	J6020	F8	N2600	M9	R7544	P8		
C2013	B7	C2809	K2	J1052	C8	J6021	F8	N3200	F2	S			
C2014	B6	C2810	L2	J1053	F6	J7515	O4	N6050	E4	S2580	T7		
C2015	A4	C2811	K4	J1054	E6	J7517	N4	N7500	O4	S2596	D9		
C2016	A5	C2812	J4	J1055	E6	J7522	O5	N7520	O4	S2597	R2		
C2020	E5	C2813	K4	J1056	D6	J7525	O5	N7540	Q7	S2598	S9		
C2021	E6	C2814	I3	J1057	G6	J7526	O5	N7541	R7	S2599	Q9		
C2071	B2	C2815	J2	J1058	F5	J7527	O5	R		T			
C2100	G7	C2819	L2	J1060	C8	J7528	O5	R1000	I4	T7500	P4		
C2101	G7	C3000	H4	J1061	C8	J7529	O4	R1001	I4	T7501	M4		
C2102	H6	C3001	H4	J1062	D7	J7530	O4	R1050	F9	V			
C2106	P3	C3002	H2	J1063	D7	J7531	O4	R1051	F9	V2000	B3		
C2107	P2	C3003	H2	J1064	E6	J7532	O4	R1052	F9	V2412	I7		
C2108	B6	C3004	I6	J2000	H5	J7533	O4	R1053	D8	V2413	H8		
C2109	H9	C3005	I6	J2001	H5	J7535	O5	R1065	D7	V2414	H8		
C2110	H9	C3006	I4	J2002	H5	J7536	Q5	R1072	C9	X			
C2111	P2	C3007	J5	J2008	B7	J7537	O5	R1078	G8	X1000	M7		
C2112	P2	C3008	I4	J2010	B7	J7538	Q6	R1080	D8	X2000	A6		
C2117	N3	C3009	J5	J2013	E5	J7550	N3	R2000	A5	X2061	F3		
C2118	N3	C3010	I4	J2014	E6	J7552	I9	R2001	B6	X2070	K7		
C2119	N2	C3100	K2	J2060	G8	J7553	O4	R2002	B5	X2400	H3		
C2120	N3	C3200	G2	J2067	H6	J7554	O4	R2003	A6	X2411	H8		
C2124	P3	C3201	G2	J2110	O2	L	R2004	A5	X2412	H8			
C2127	P3	C3202	G3	J2206	H6	L1000	M8	R2005	A7	X2580	C5		
C2132	H9	C3203	G2	J2207	H6	L1001	L6	R2006	A7	X2700	D8		
C2200	G7	C3221	E5	J2209	H6	L1050	F6	R2009	A7	X3200	D3		
C2201	J6	C6000	E3	J2218	I8	L1051	G5	R2010	A8	X8000	R2		
C2202	H6	C6001	E3	J2219	I7	L1052	F9	R2011	B4	X8001	T2		
C2203	I7	C6002	D4	J2306	H4	L1053	F9	R2012	A4	X8002	T2		
C2204	H7	C6003	D2	J2307	G4	L1067	F7	R2013	A4	X8003	S8		
C2205	H7	C6004	D4	J2308	G4	L2002	A6	R2015	B4	X8004	R9		
C2206	H7	C6005	D2	J2309	H4	L2003	B7	R2016	B4	X8005	R9		
C2207	J7	C6010	E3	J2310	H4	L2004	B8	R2017	J7	X8006	T3		
C2208	I6	C6011	E2	J2314	H4	L2006	B6	R2018	H7	X8007	C2		
C2209	I6	C6050	E4	J2700	E8	L2100	B5	R2022	B6	X8008	J8		
C2210	I9	C6051	E3	J2701	E8	L2101	O3	R2023	D5	X8009	O8		
C2211	I9	C6052	E4	J2702	E8	L2102	M2	R2069	B2	X8010	S2		
C2212	J8	C7500	O3	J2703	E8	L2103	N2	R2070	B2	X8011	S9		
C2215	J8	C7501	M5	J2818	I2	L2104	O2	R2071	J7	X8012	S2		
C2217	J7	C7502	M5	J2819	K2	L2105	H9	R2100	G6	X8013	J2		
C2220	I9	C7503	O3	J2820	K2	L2107	O2	R2101	H6	X8014	T4		

